

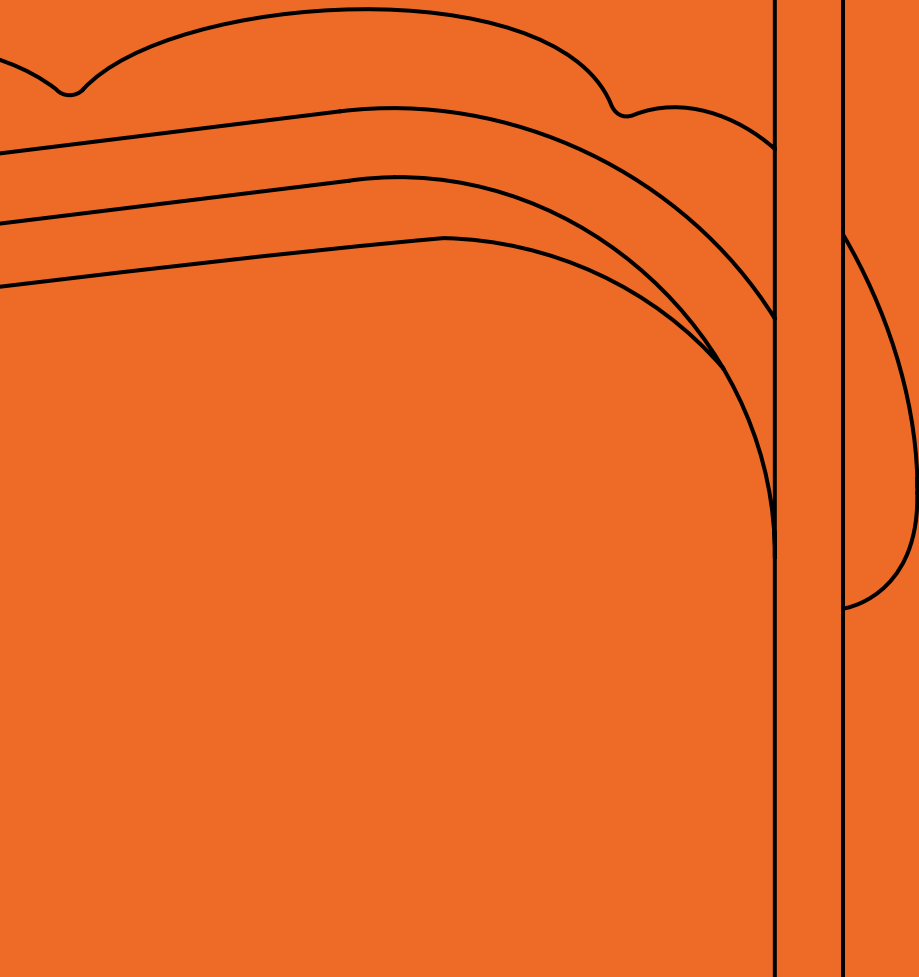

LAMMHULTS













News	11
Space matters	33
A collaborative practice	87
A brief history	95
Products A-X	101
Sustainability	Appendix

News

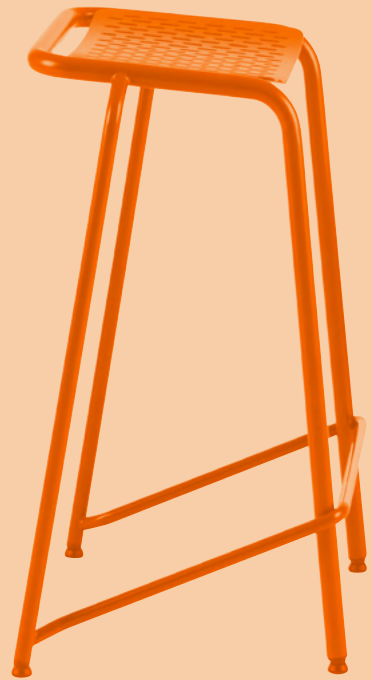

Our design philosophy can be summed up with two words: Space matters. So, it's no coincidence that this year's new products from Lammhults have been designed with careful attention paid to space and surroundings. Anya Sebton's A22 stool series is made entirely of steel and without any screws or bolts, so its material can be easily recycled and reused. Atlas Air, a new office chair by Johannes Foersom and Peter Hiort-Lorenzen, is devoid of any composite materials and consists entirely of separable parts to facilitate repairs and eventually recycling. Another new addition this year is an oval side table by Gunilla Allard and Note Design Studio for Sunny, their award-winning easy chair. The table is available in several versions, one being made of recycled plastic.



A22

Design: Anya Sebton

A22 is a stackable, highly versatile stool designed for impromptu meetings and quick breaks in dynamic environments. Its comfortable seat is angled slightly forward to encourage occupants to stand occasionally and do their bodies a favour. The leg frame consists of curved steel tubes in three different diameters. This interplay of thinner and thicker lines gives A22 its striking graphic character, which is accentuated by the seat surface's laser-cut pattern.

It is also designed for movement and change. A gap between its tubular frame and the back edge of the seat creates an integrated handle for easy moving and lifting. An add-on cushion simply wraps over the seat surface like a scarf. A22 is available in three different heights.

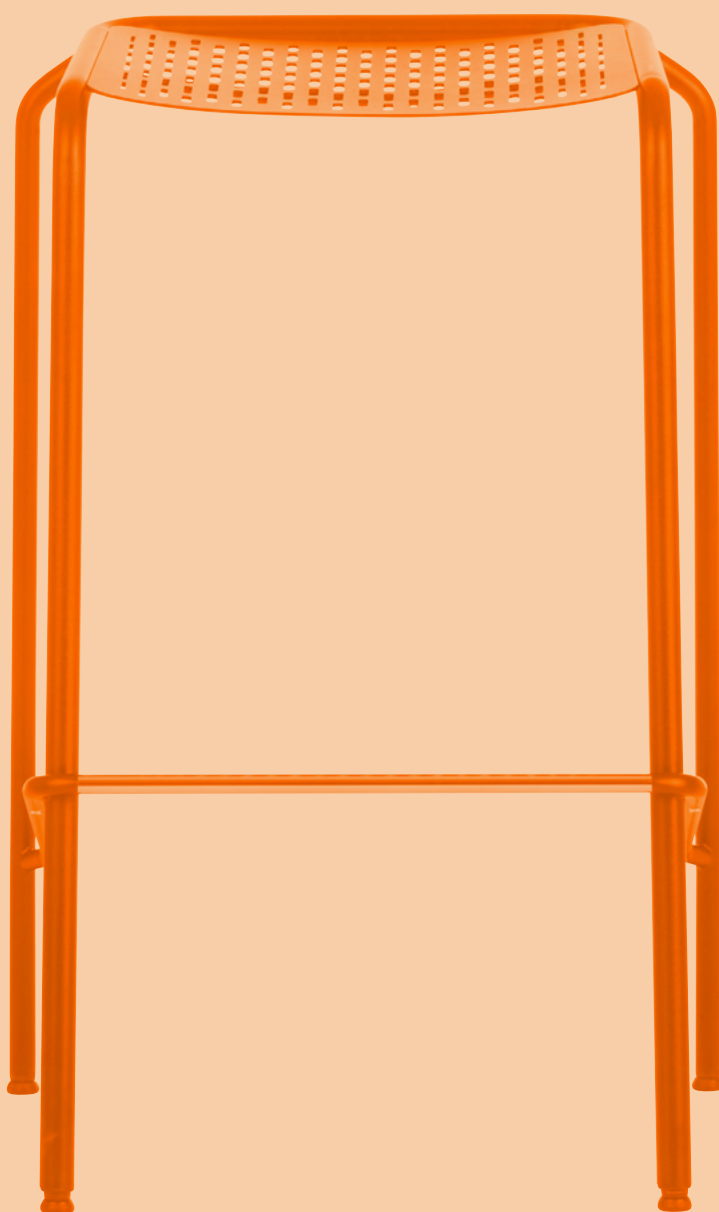

My aim is to create long-lasting products by
ombining durable materials with timeless design.

— Anya Sebton







ATLAS AIR

Design: Johannes Foersom & Peter Hiort-Lorenzen

Atlas Air combines qualities such as sustainability, elegant form, thin lines, lightness, and exceptional comfort. It is an office chair that lets you work in comfort and peace — by supporting your body properly and allowing you to move it freely.

Atlas Air's lightness is not only rooted in design but material composition. The cast, recycled aluminium frame, armrest and back arch reduce the chair's weight and environmental footprint. The seat is made of wear-resistant mesh, which contributes to the chair's slender, lightweight appearance. The mesh seat is available in four colours. There is also a version of Atlas Air with a quilted cushion in fabric or leather.

Both a 4-foot swivel base with glides and a height adjustable 5-foot swivel base with casters or glides are available.



This is a piece that can be used as an office chair, a conference chair, or a chair for visitors. It fits as well in a work or institutional setting as it does in your home.

— Peter Hiort-Lorenzen





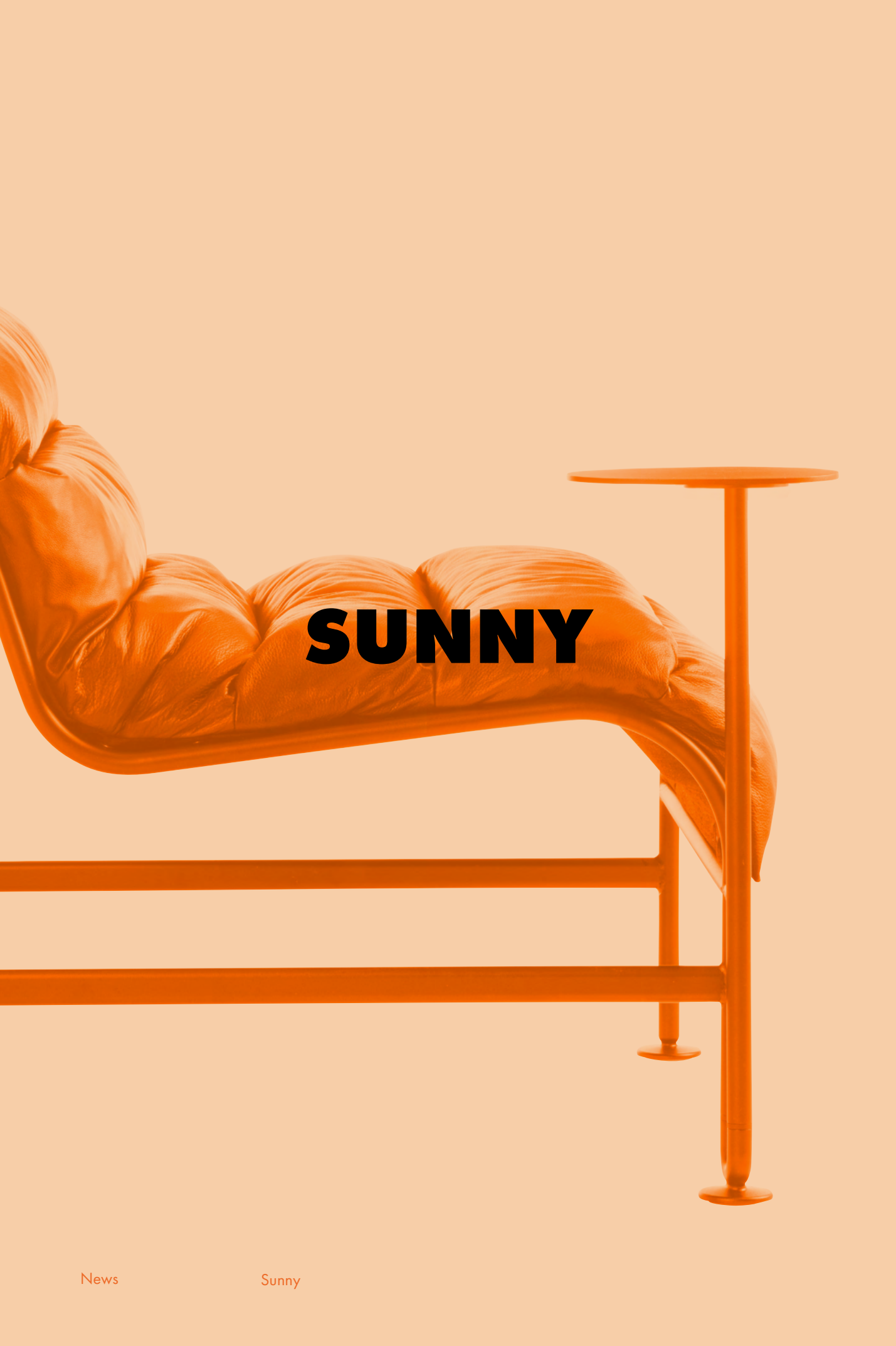

SUNNY

Design: Gunilla Allard & Note Design Studio

This year, the designers have complemented Sunny with an oval-shaped metal side table for one's coffee cup or laptop. "We got the idea from the shape of puddles and ice patches," explains Allard. "The chromed version gives the impression of a mirrored sheet of water. There's also a version of the table made of recycled plastic."

The new side table underscores an essential detail that is key to the Sunny concept: a u-shaped foot that, in this case, connects the table's single leg to the seat's leg frame. This ingenious feature allows functions to be added and seat modules to be combined to create larger furniture pieces and shapes for different types of rooms and ways of using space.

Sunny is suitable for both home and office; for general public settings, as well as thoughtfully designed retail environments. The seat can be employed as a solitary lounge chair or as a modular component in a variety of seating configurations. Sunny is also available with armrests, and on casters.



We got the idea for the oval-shaped table top from the shape of puddles and ice patches. The chromed version gives the impression of a mirrored sheet of water.

— Gunilla Allard





Space matters



Our heritage from modernism, and over 75 years of furniture making in collaboration with great designers, have made us optimists. We are convinced that design can change the world.

The ecological crisis, pandemics, and new technologies challenge our habitual ways of living. They urge us to rethink how we work, consume, travel, and socialize. The essential role of design today is to evoke hope and to explore new, sustainable ways of understanding and forming our surroundings.

At Lammhults, we know that space matters. Our everyday surroundings have a strong influence on us. Our aim as a furniture maker is to improve the spaces where people work, play, come together, fall in love, and recover. To make them more meaningful, valuable, functional, durable, and beautiful.

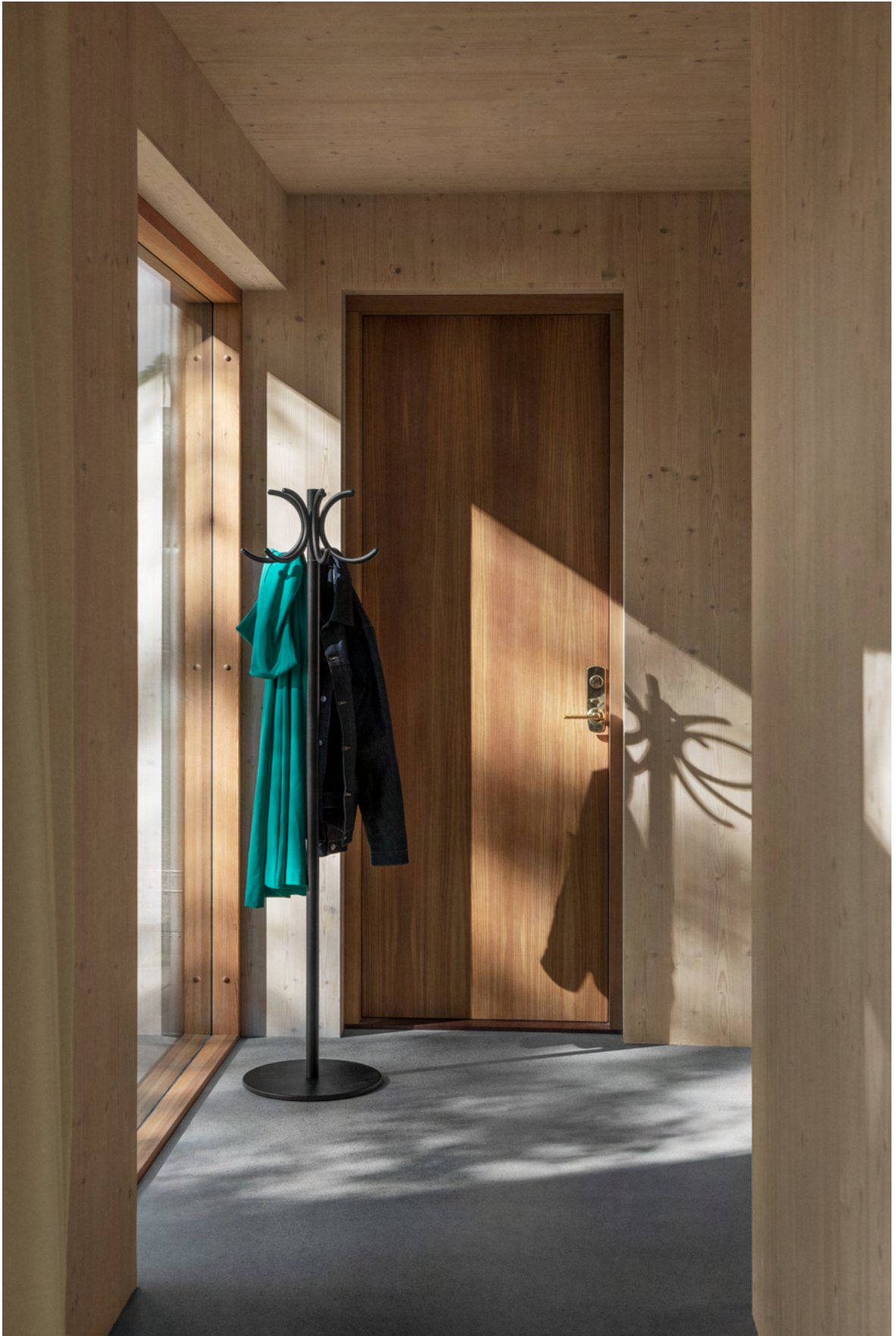

S70-12 Coat hanger







SUNNY Easy chair

127







CAJAL Table

113

CAJAL Sofa

112



CORSO Easy chair



CAROUSEL Armchair





PONTO Table

122

GRADE Chair

120







APERI Easy chair/Sofa

107

CHICAGO Trolley

117



APERI Easy chair



SUNNY Easy chair/Modular seating

Our aim as a furniture
the spaces where peo
together, fall in love, a

maker is to improve
people work, play, come
and recover.







FUNK Table

119

GRADE PLUS Armchair

120

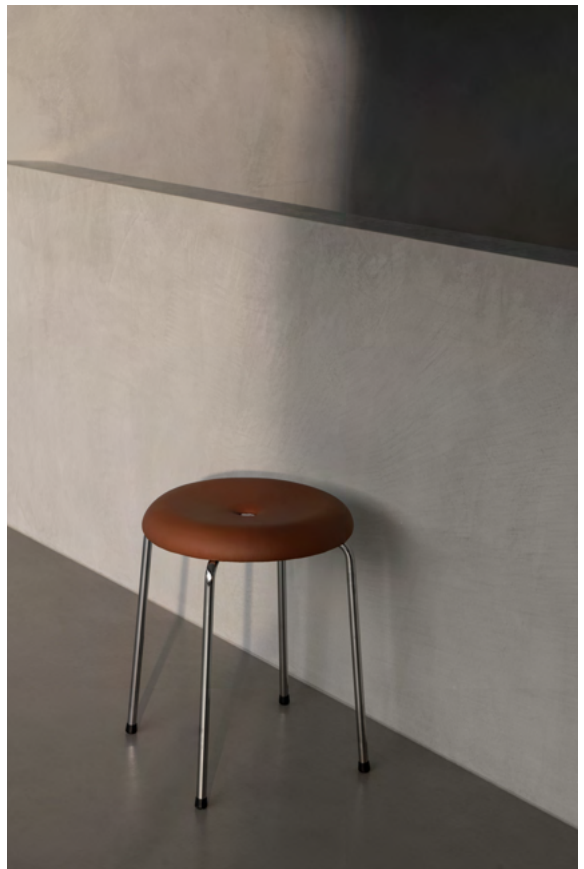

TABURETT Stool



SPIRA Armchair



ARCHAL XL CONFERENCE Armchair 108

PONTO Table

121









A22 Barstool









ATTACH Table

112

ADD Chair

104





PENNE Chair

121

CAMPUS CAFÉ Table

114



PORTUS Sofa









AREA RADIUS Modular seating

111

ADD CABLE TABLE Table

104



CINEMA Easy chair



CAMPUS Chair

113

CAMPUS CAFÉ Table

115



S70-4 Easy chair





SPIRA Chair

126

CHICAGO Trolley

117



QUICKLY Table

124

TRIOO Chair

128



ARCHAL XL CONFERENCE Armchair 108

A collaborative practice



LAMMHULTS MÖBEL AB

Making furniture requires a rich combination of ingredients — not only hard skills, but creativity, imagination, craftsmanship and, not least, tacit knowledge.

The heart of our business is where it's been from the beginning: in Lammhult, an idyllic little town in south-central Sweden. This is where everything happens, where ideas and visionary concepts materialise — first as prototypes and ultimately as works of furniture. Here, we have our mechanical workshop, powder coating facility, and an assembly line, as well as our upholstery and sewing studios.

Our factory is more than just a place for manufacturing furniture. It is the environment within which a unique creative culture and perspective on design have evolved and will keep evolving. To us, furniture making is a collaborative endeavour that brings together manifold skills, fields of knowledge, and experiences.



The Lammhults do-it-together spirit has brought about a culture of creativity, tolerance, thoughtfulness, gender equality, good humour, and work satisfaction. We embrace diversity. It's a resource that makes working together more enriching, rewarding and fun. We know that the differences amongst us keep us growing as individuals and getting better at what we do.

We have a particular liking for things that last. That includes our relationships with our designers, clients, suppliers and employees. Indeed, the long-standing relationships we share with our talented co-workers and a number of today's most renowned furniture designers continue to shape our company. At the same time, we are always open to working on new projects with new designers, as well as with creators from other fields, including architecture, fashion, the arts, and gastronomy.

Designers of Lammhults



Andrés Nilson



Anya Sebton



Börge Lindau & Bo Lindekrantz



Edvin Ståhl



Gunilla Allard



Gunilla Allard & Note Design Studio



Johannes Foersom & Peter Hiort-Lorenzen



Marcus Keichel & Julia Läufer



Peter Andersson



Troels Grum-Schwensen

Lammhults was a brilliant school for me as a young designer. It was a really open-minded place where we were constantly experimenting and testing new ideas. In fact, the company demanded originality. So, I explored what interested me — working on my fine-lined, graphic designs and figuring out how to make them solid and resilient at the same time. And then you have the enduring relationships with designers like me, Anya, Peter and Johannes — that's something quite unusual, nowadays. Lammhults is like a family. There's a lot of love and plenty of history.

— Gunilla Allard

A brief history



Lammhults was founded in 1945 when entrepreneur and furniture enthusiast Edvin Ståhl opened a mechanical workshop in his small hometown of Lammhult in southern Sweden. Little did he know at the time that his small start-up would play an influential role in the success story of Scandinavian modernism. Much has happened since, but Lammhults is still based in Lammhult and one of Ståhl's early designs remains available today: the Taburett stool from 1955, a modest incarnation of the democratic and functionalist ideals of modernist design.

In the early decades, Ståhl himself designed most of the Lammhults furniture portfolio. This changed in the 1960s when nephew Kenneth Ståhl, the company's new sales director, brought acclaimed young designers Börge Lindau and Bo Lindekrantz on board, thus beginning the transformation of Lammhults into a modern, design-oriented company where playful creativity was and remains a guiding principle. Eventually, Lammhults became a platform not only for innovative and experimental designers but for other creators, such as free-thinking graphic designers John Melin and Hans-Christer Ericsson, whose poster art and catalogues pushed the boundaries of how it was thought a furniture company could present itself.



Since then, several selected designers have left their mark on Lammhults — not least Anya Sebton, the Danish duo Johannes Foersom and Peter Hiort-Lorenzen, and Gunilla Allard. Allard began collaborating with the company in the late 1980s, upon completing her studies at Konstfack. Allard, in turn, has introduced a new generation of furniture designers to the company through her work on the Sunny armchair and sofa, launched in 2021. Sunny was a collaborative project between Lammhults, Allard, and multidisciplinary Note Design Studio.

Despite all the changes over the long history of Lammhults, a number of fundamental things remain: a belief that design is a powerful tool for improving people's living environments; a belief in craftsmanship and sturdy materials; a long-term perspective on furniture form and function; a sustainable view on resources; a commitment to the local economy and community; and pride in the company's heritage in Lammhult, where it still operates.

Products A-X

What does it actually mean for a furniture piece to be timeless? For one thing, that it can be used for a long time without ever feeling outdated. The piece remains meaningful and may even become more beautiful as the years pass. Despite what it might be understood to imply, timeless does not mean that the piece is divorced from time. On the contrary, many furniture pieces that are perceived as timeless are very much rooted in their time and go on to function as icons of that time, embodying values that endure and remain relevant long after first being expressed. At Lammhults, we are proud to have many such furniture pieces in our portfolio, from the new A22 to X75-2 from 1968.

A22

Design: Anya Sebton

The world is moving away from a linear economy to a circular one — where raw materials used to manufacture goods can ultimately be recycled and reused to make new goods, again and again. A22 is a furniture piece designed for this essential shift. "My aim is to create long-lasting products by combining durable materials with timeless design," says Anya Sebton. To facilitate recycling and reuse, the stool is made entirely of steel, without any bolts or screws. A22 is a stackable, highly versatile stool designed for impromptu meetings and quick breaks in dynamic environments. An add-on cushion simply wraps over the seat surface like a scarf. A22 is available as a stool or a barstool.

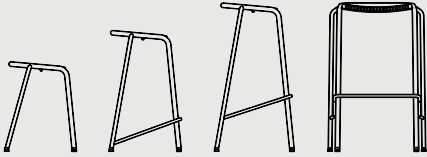

Stool/Barstool

2022

Frame of Ø25 & 20 mm powder coated steel tubing, footrest of Ø15 mm chromium plated steel tubing. Glides. Seat of 3 mm powder coated perforated sheet steel. Loose reversible pad as an option. Stackable.

Height: 500/670/820 mm

Width: 530/540/540 mm

Depth: 400/400/440 mm

Seat height: 460/630/780 mm

ADD

Design: Anya Sebton

Add is a furniture series for contemporary work spaces that demand a high degree of versatility and functionality, as well as impeccable aesthetics and resilience. The Add and Add Move chairs and stools combine neat, uncomplicated looks with maximum comfort. Designed for a dynamic work environment, Add offers its users the perfect ergonomic seating position, so they can focus on the task at hand. Two versatile side tables — Add Cable Table and Add table — along with Add accessories, including a coat hanger, a magazine rack and a storage box rack reflect the simplicity and functionality of the series as a whole.

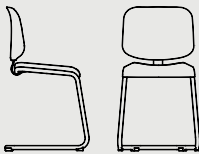

Chair

2015

Frame of 22 mm powder coated or chromium plated steel tubing. Casters come in chrome, black or white. Seat of molded wood with black polyurethane or upholstered seat with high resilient polyurethane foam. Back of black polyurethane alt. upholstered. Suspendable with built-in slide protection.

Height: 800 mm

Width: 480 mm

Depth: 560 mm

Seat height: 460 mm

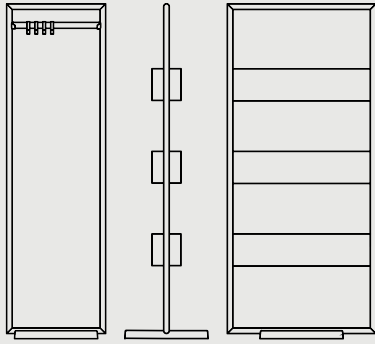

Coat hanger/Magazine rack/Storage rack

2014

Foot plate in texture powder coated, black or white, casted iron. Adjustable feet. Optional: swivel foot plate. Frame of 28 mm powder coated steel tubing, width 50 or 75 cm. Clothes rail in chromium plated oval steel tubing 30x15 mm or in natural ash. Hooks in black or white polyamide. Width 50 cm incl. 4 hooks, width 75 cm incl. 6 hooks. Magazine rack incl. 3 pcs of powder coated perforated iron boxes. Storage rack incl. 3 pcs of powder coated iron boxes. Optional: umbrella stand, linking device, insert for plants.

Height: 1700 mm

Width: 500/750 mm

Depth: 420 mm

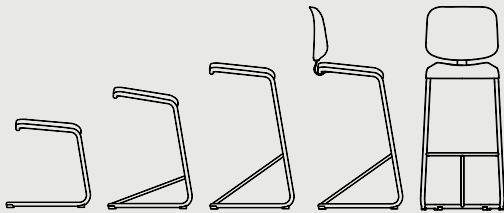

Stool/Barstool

2014

Frame of 22 mm powder coated or chromium plated steel tubing. Footrest always in chrome. With or without glides. Seat of molded wood with black polyurethane or upholstered seat with high resilient polyurethane foam. Back of black polyurethane alt. upholstered. Suspendable with built-in slide protection. Upholstery available in fabric or leather.

Height: 460/670/810 mm

Width: 460 mm

Depth: 470 mm

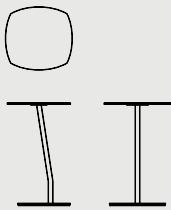

Table

2014

Frame with foot plate of powder coated or chromium plated steel and powder coated pillar of 25 mm steel tubing. Table top of 3 mm powder coated steel sheet. Felt glides. Optional: removable cork top.

Height: 560/660 mm

Width: 370 mm

Depth: 350 mm

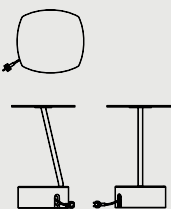

Add Cable Table

Table

2018

Texture powder coated spin formed steel foot with pillar of 25 mm steel tubing. Table top of 3 mm texture powder coated steel sheet. Felt glides. Incl. 5 m retractable cord reel. Anthracite outlets in two versions: 2 power outlets or 1 power outlet + 1 USB A + 1 USB C.

Height: 660/560 mm

Width: 370 mm

Depth: 350 mm

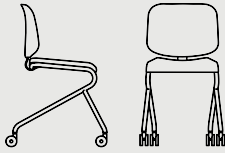

Add Move

Chair

Frame of 22 mm powder coated or chromium plated steel tubing. Casters come in chrome, black or white. Seat of molded wood with black polyurethane or upholstered seat with high resilient polyurethane foam. Back of black polyurethane alt. upholstered. Suspendable with built-in slide protection.

Height: 800 mm

Width: 480 mm

Depth: 560 mm

Seat height: 460 mm

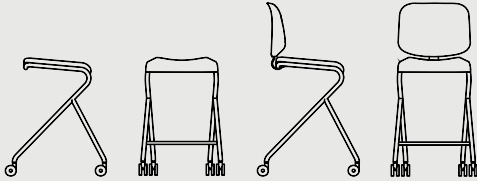

Add Move

Stool/Barstool

2016

Frame of 22 mm powder coated or chromium plated steel tubing. Casters come in chrome, black or white. Seat of molded wood with black polyurethane or upholstered seat with high resilient polyurethane foam. Back of black polyurethane alt. upholstered. Suspendable with built-in slide protection.

Height: Stool/Barstool/Barstool w. back
490/660/960 mm

Width: 480 mm

Depth: 560 mm

Seat height: 460/630 mm

ADDIT

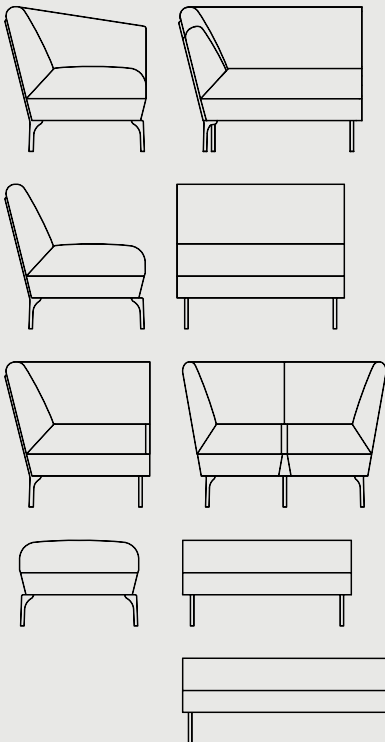

Design: Anya Sebton

Addit enables you to create a seating solution that adapts altogether to the function, size, and character of the room. Its innovative magnetic linking device, Quicklink, developed by Lammhults, makes it easy to combine the upholstered modules into comfortable sofas of various shapes and sizes. Each module can also function as an independent furniture piece. Addit consists of six different modules and two ottomans. The exposed steel tubing that distinctively frames the pieces is available with a powder coated or chromed finish.

Modular seating

2012

Legs of powder coated or chromium plated cast aluminum. Felt glides. Back frame of Ø19 mm powder coated or chromium plated steel tubing. Shell of plywood with polyether foam. Built-in magnetic linking device.

Height: 470/800 mm

Width: 920/1000/1110/1370 mm

Depth: 650/770 mm

Seat height: 470 mm

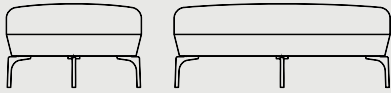

Ottoman

2013

Legs of powder coated or chromium plated cast aluminum. Felt glides. Shell of plywood with polyether foam.

Height: 470 mm

Width: Ø750/ 1200 mm

APERI

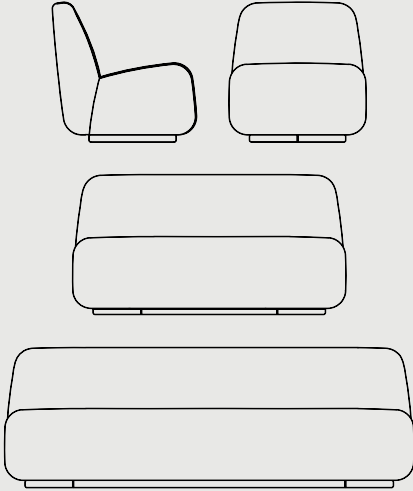

Design: Julia Läuffer & Marcus Keichel

The compact shape of Aperi brings to mind a monolith — albeit an unusually soft one. Sculptural yet welcoming, it is a furniture piece that awakens associations and makes its indelible mark on the spaces it inhabits. Aperi is inspiring to create interiors with — and equally delightful to sink into for a conversation or a moment of mellow reflection. Aperi is available as an easy chair and as a two- or three-seater sofa.

Easy chair/Sofa

2016

Powder coated metal base with adjustable feet. Seat with nozag. Polyurethane foam padding in the seat and back.

Height: 780 mm

Width: 760/1500/2260 mm

Depth: 800 mm

Seat height: 440 mm

ARCHAL

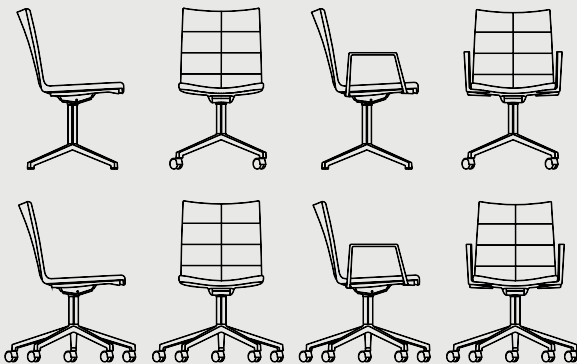

Design: Johannes Foersom & Peter Hiort-Lorenzen

Archal is a family of comfortable chairs for different types of spaces — from offices and meeting rooms to public or home environments. Its style stems from a geometrically driven design that gives free expression to the frame's form and materials. Manufactured by one of Lammhults' local partners, the frame is made of 99.9% recycled aluminium. How much aluminium goes into one frame? About 360 soft drink cans. The Archal family includes Archal chair, the more generously proportioned Archal XL chair with wider armrests and extra padding, and the Archal T & X tables, also with frames made of cast recycled aluminium.

Chair/Armchair

2011

Frame of recycled, cast aluminum, texture powder coated or polished, in two different models:

- 4-feet swivel base, 360°, incl. glides. Option: Memory return and casters.
- 5-feet height adjustable swivel base, 360°, incl. casters.

Fully upholstered seat shell incl. quilting. With or without armrests of recycled cast aluminum, texture powder coated or polished.

Height: 800/800–850 mm

Width: 500/510/555/570/670 mm

Depth: 570/670 mm

Seat height: 450/450–500 mm

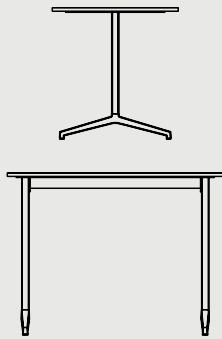

Archal T

Table

2014

Legs of cast aluminum, texture powder coated or polished. Frame of galvanized rectangular steel tubing 40x20 mm. Linkable. Table top of 19 mm fibre board in the following versions:

- Melamine: white/grey, graphite or birch decor with matching plastic edge.
- High pressure laminate: Formica Collection Colors with matching plastic edge.
- Veneer: natural ash, oak or birch alt. stained ash with matching wooden edge.
- Linoleum: Forbo Linoleum with matching edge.

Height: 720/900/1100 mm

Length: 1200–1800 mm

Width: 600–900 mm

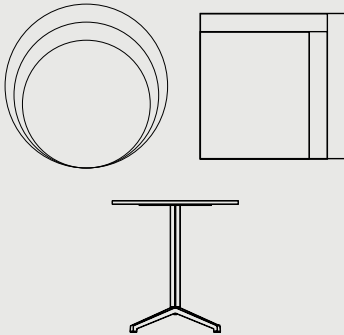

Archal X

Table

2014

Legs of cast aluminum, texture powder coated or polished. Frame of galvanized rectangular steel tubing 40x20 mm. Table top of 19 mm fibre board in the following versions:

- Melamine: white/grey, graphite or birch decor with matching plastic edge.
- High pressure laminate: Formica Collection Colors with matching plastic edge.
- Veneer: natural ash, oak or birch alt. stained ash with matching wooden edge.
- Linoleum: Forbo Linoleum with matching edge.

Height: 620/730/900/1100 mm

Width: 600/700/800 mm

Depth: 700/800 mm

Ø700/800 mm

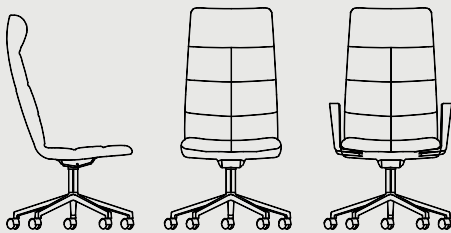

Archal XL — Conference

Chair/Armchair

2018

5-foot height adjustable swivel base, 360°, of polished or texture powder coated cast recycled aluminum. Casters. Armrests of polished or texture powder coated cast recycled aluminum. Fully upholstered with quilting. Optional leather arm covers.

Height: 1220–1270 mm

Width: 670 mm

Depth: 670 mm

Seat height: 470–520 mm

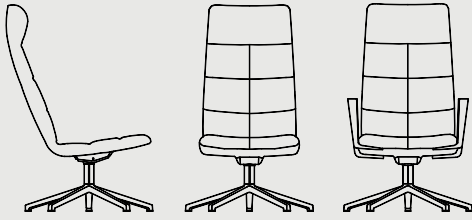

Archal XL — Lounge

Easy chair

2018

5-feet swivel base, 360°, of polished or texture powder coated cast recycled aluminum. Glides. Armrests of cast recycled aluminum, texture powder coated or polished. Fully upholstered with quilting. Optional leather arm covers.

Height: 1090 mm

Width: 670 mm

Depth: 670 mm

Seat height: 420 mm

AREA

Design: Anya Sebton

Area is a flexible, colourful and bold modular seating series designed to meet the diverse needs of today's workspaces. The modules can be stand-alone or combined into sofa pieces of different shapes and sizes. Quicklink, an innovative linking device, makes it easy to create new configurations. Area and Area Radius enable you to transform a workspace into exactly what you want it to be: a meeting room, a recreation area, a casual lounge, or a multifunctional space to meet a variety of needs. The modules are available with a high or low back. High-back modules improve the acoustic environment and allow you to create separate areas within a room.

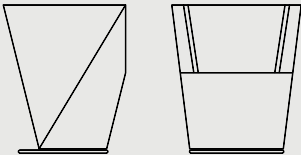

Easy chair

2013

Sled base of Ø22 mm powder coated or chromium plated steel tubing. Glides. Felt glides. Shell of fibre board with high resilient polyurethane foam.

Height: 830 mm

Width: 720 mm

Depth: 680 mm

Seat height: 450 mm

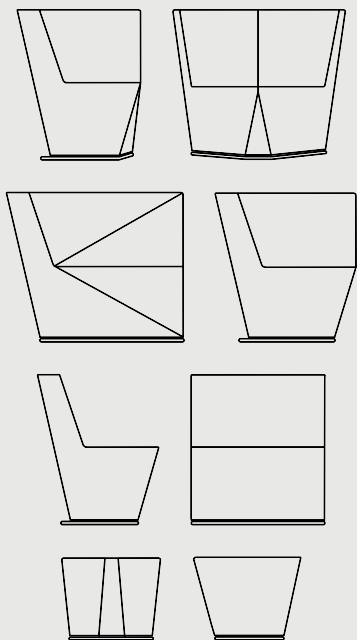

Modular seating

2009

Right/left unit, center unit, corner unit and a foot stool with base of $\varnothing 22$ mm chromium plated or powder coated steel tubing. Glides. Modules with high back incl. adjustable feet. Shell of fibre board with high resilient polyurethane foam. Built-in magnetic linking device.

Table with frame of $\varnothing 10$ mm powder coated solid steel with 2 mm powder coated perforated steel sheet. Base of $\varnothing 22$ mm powder coated steel tubing. Glides.

Height: 830 mm

Width: 740/980/950 mm

Depth: 680/780 mm

Seat height: 450 mm

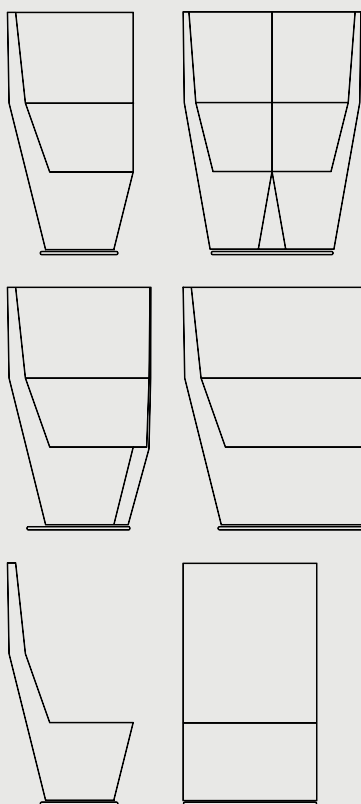

Area High

Modular seating

2013

Right/left unit, center unit, corner unit with base of $\varnothing 22$ mm chromium plated or powder coated steel tubing. Glides incl. adjustable feet. Shell of fibre board with high resilient polyurethane foam. Built-in magnetic linking device.

Height: 1330 mm

Width: 740/990 mm

Depth: 690/790 mm

Seat height: 450 mm

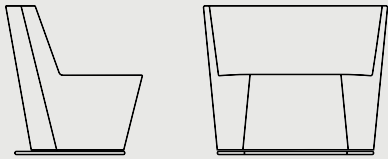

Area Radius

Modular seating

2016

Sled base of 22 mm powder coated or chromium plated steel tubing. Glides. Shell of fibre board with high resilient polyurethane foam. Built-in magnetic linking device. Can be linked with all Area models.

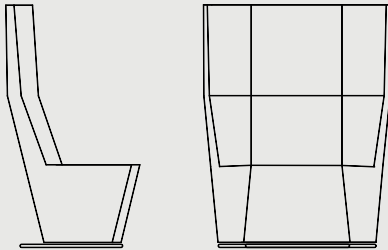

Height: 830/1330 mm

Width: 1020/1360 mm

Depth: 680/690 mm

Seat height: 450 mm

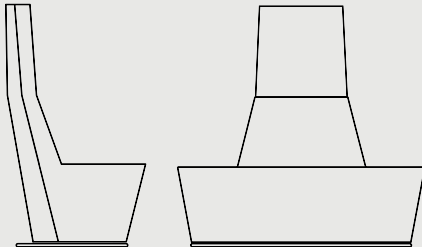
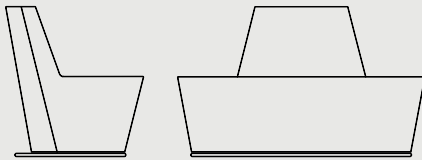

ATLAS AIR

Design: Johannes Foersom and Peter Hiort-Lorenzen

Atlas Air combines qualities such as sustainability, elegant form, thin lines, lightness, and exceptional comfort. It is an office chair that lets you work in comfort and peace — by supporting your body properly and allowing you to move it freely. Atlas Air's lightness is not only rooted in design but material composition. A cast, recycled aluminium frame reduces the chair's weight and environmental footprint. The seat is made of wear-resistant mesh, which contributes to the chair's slender, lightweight appearance.

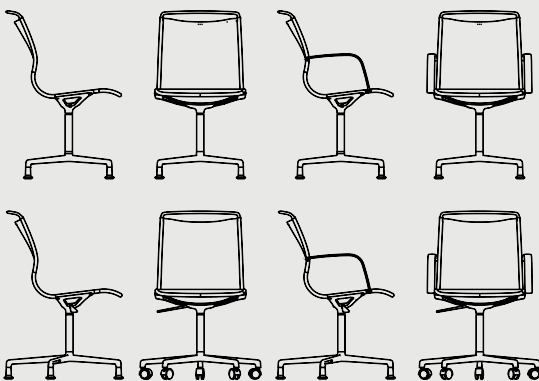

Chair/Armchair

2022

4-feet swivel frame of cast recycled aluminium, powder coated or polished incl. glides. 5-feet, height-adjustable, swivel frame of cast recycled aluminium, powder coated or polished incl. casters. Glides against additional cost. Height-adjustable pillar for 4-feet against additional cost. Back arch and armrests of powder coated or polished cast recycled aluminium. Seat shell in white, grey, black or rust brown mesh with flocked surface. Replaceable pad attached with push buttons available as an option. Note! The pad can't be retrofitted on version without pad.

Height: 920/920/920–1000 mm

Width: 500/580/660 mm

Depth: 630/630/660 mm

Seat height: 460/460/460–540 mm

ATTACH

Design: Troels Grum-Schwensen

In designing Attach, Troels Grum-Schwensen summoned the basic principles of physics. Its legs, which connect easily to sleek beams beneath the table top, are secured by gravity. Meanwhile, the beams and the legs are made of recycled aluminium. Attach has received several awards for its ingenious fusion of technology and art. Its innovative system makes it possible to create a multitude of shapes and sizes, including very large tables. Attach is available in two different heights.

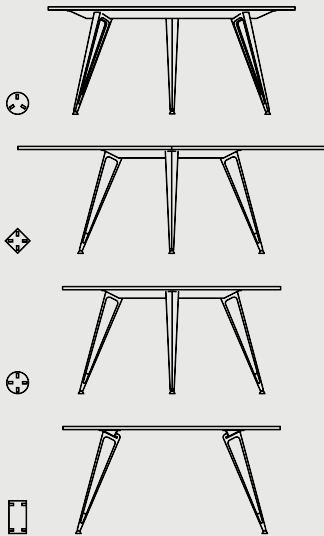

Table

2016

Legs of die-cast, powder-coated aluminum. Alternatively in white or black lacquer finish with polished sides. Beams of extruded anodized recycled aluminum with transparent or black end caps. Choose from the border to stop 1 cm or 31 cm from the table's short side. Adjustable feet in black acetel. Table top of 22 mm wooden board in the following versions:

- Veneer: natural ash or oak alt. stained ash with matching wooden edge.
- Linoleum: Forbo Furniture with matching plastic edge.
- High Pressure Laminate: white with matching plastic edge. — Melamine: white with matching plastic edge.
- Melamine Perfect Sense matt anti-fingerprint surface, black Matching plastic edge.

Height: 740/900 mm

Length: 1600–9600 mm

Width: 900–2000 mm

Ø1000–2000 mm

CAJAL

Design: Gunilla Allard

Cajal brings structure decisively to the fore. It is a collection of furniture where form is synonymous with construction. Through it, designer Gunilla Allard pays homage to the legacy of modernism and celebrates its values of honesty and transparency. Exposed steel tubing frames the back of the sofa "as if with the stroke of a pen or a kajal pencil," remarks Allard. The collection consists of two differently sized sofas, an easy chair, and a table in several sizes.

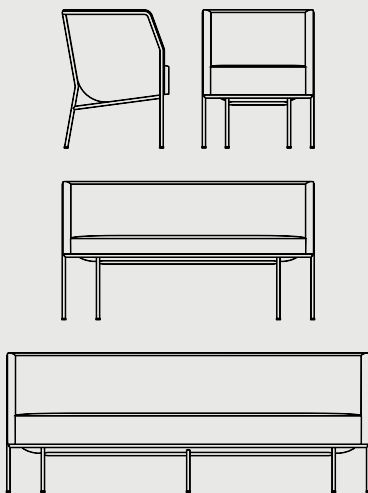

Easy chair/Sofa

2014

Frame of 18 mm powder coated or chromium plated steel tubing. Glides. Molded shell of glass fibre reinforced polyurethane. Seat in plywood with molded high resilient polyurethane foam. Large sofa incl. pocket-spring.

Height: 770 mm

Width: 620/1400/2000 mm

Depth: 570/590/650 mm

Seat height: 420/450 mm

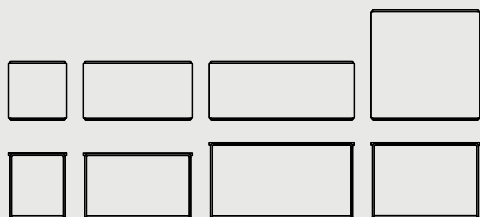

Table

2015

Frame of $\varnothing 12$ mm powder coated or chromium plated solid steel. Glides. Table top of 16 mm plywood with natural or stained ash veneer alt. linoleum, mushroom or charcoal. Lacquered edge. Size 40x40 cm also available in Carrara marble.

Height: 450/520 mm

Width: 400/750/1000 mm

Depth: 400/750 mm

CAMPUS

Design: Johannes Foersom & Peter Hiort-Lorenzen

Thirty years have passed since Campus was first launched. Back then, the chair quickly achieved success both in Scandinavia and around the globe. Having left its mark on many contemporary environments, the piece is today considered a classic. The reason it's been such a hit? Perhaps because it works just as well alone as it does in large numbers. The stackable chair possesses a vitality and simplicity that bears repeating — without becoming repetitive. The designers explain: "Our focus with Campus was always on all the requirements that are at play when you're situating a lot of chairs in one space." Today, the Campus collection includes several products: Campus and Campus Air chair, Campus and Campus Air barstool, Campus table, and Campus Café table.

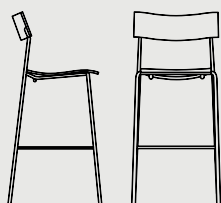

Barstool

2007

Frame of $\varnothing 16$ mm powder coated or chromium plated steel. Seat and back of natural ash, birch or oak alt. stained. Alt. upholstered seat or fully upholstered.

Height: 950/1100 mm

Width: 490 mm

Depth: 530 mm

Seat height: 630/780 mm

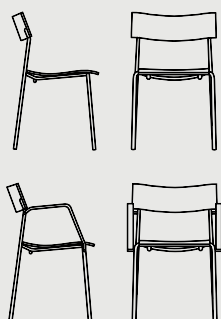

Chair/Armchair

1992

Frame of $\varnothing 16$ mm powder coated or chromium plated steel tubing. Seat and back in birch, ash or oak, upholstered seat alt. fully upholstered. Armrests in matching wood. Stackable and linkable.

Height: 760 mm

Width: 470/530 mm

Depth: 490 mm

Seat height: 450 mm

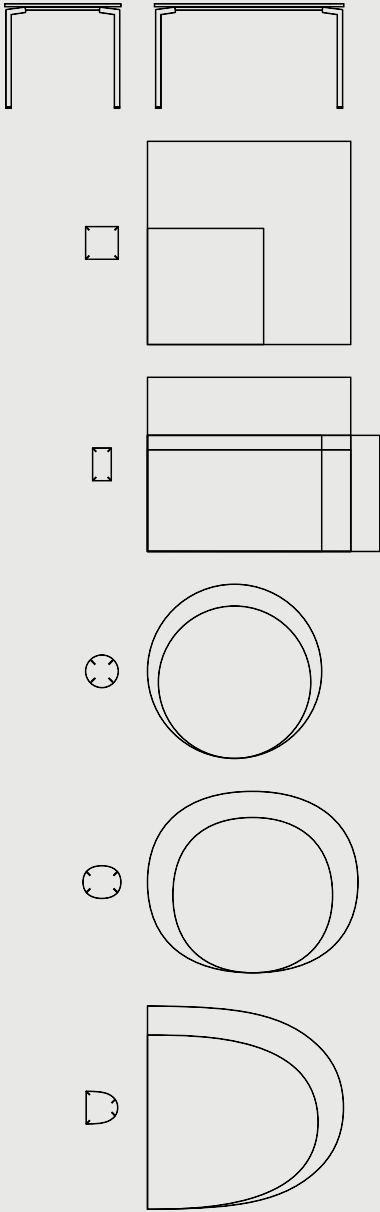

Table

1993

Legs of flat-oval powder coated or chromium plated steel tubing 40x20 mm. Frame of galvanized steel tubing 40x20 mm. Top of 19 mm chip board with melamine off-white and matching plastic edges. Adjustable feet.

Height: 720 mm

Width: 800/1200/1400/1600 mm, \varnothing 1050/1200 mm

Depth: 700/800/1200/1400 mm

Oval: 1070x1100/1250x1450 mm

Half oval: 1170x1200/1350x1400 mm

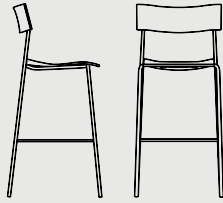

Campus Air

Barstool

2008

Frame of Ø16 mm powder coated or chromium plated steel tubing. Seat and back of glass-fiber reinforced polyamide. Available in white, light grey, grey, black, orange, red, blue green or blue polyamide. alt. with upholstered seat.

Height: 950/1100 mm

Width: 490 mm

Depth: 530 mm

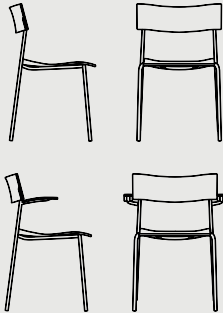

Campus Air

Chair/Armchair

2008

Frame of Ø16 mm powder coated or chromium plated steel tubing. Frame for outdoor use is available. Seat, back and armrests of glass-fiber reinforced polyamide. Available in white, light grey, grey, black, orange, red, blue green or blue polyamide. alt. with upholstered seat. Other colors on request. Armchair suspendable from table. Optional: Armrests in steel-reinforced black polyurethane. Stackable and linkable.

Height: 760 mm

Width: 470/560 mm

Depth: 490 mm

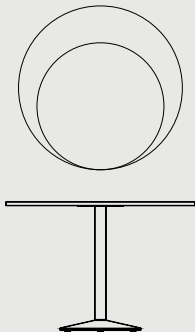

Campus Café

Table

1997

Pedestal base with cast iron foot, powder coated. Adjustable feet as standard. Foot plate: Ø45 cm. Table top of 19 mm fibre board in the following versions:

- Melamine: (white/grey, alt. graphite) or birch decor with matching plastic edge.
- High pressure laminate: Formica Collection Colors with matching plastic edge when possible.
- Veneer: natural ash, oak, birch or beech with matching wooden edge.
- Stained ash: white/grey or graphite with matching wooden edge.
- Linoleum: Forbo Furniture with matching edge when possible.

Height: 720 mm

Width: 700/800 mm, Ø700/800 mm

Depth: 700/800 mm

CARGO

Design: Gunilla Allard

There are furniture pieces whose very presence can elevate the mood of an entire room; that enliven spaces which would otherwise be dull and ordinary. Cargo, a trolley designed by Gunilla Allard, is one such piece. Its natural elegance permeates its surroundings. The materials from which Cargo's various iterations are made — such as leather, stainless steel and marble — are selected with care. The combination of these materials differs from one iteration of Cargo to the next, each having been conceived to create dynamism through a marriage of opposing material characteristics. A mirrored finish contrasts with matte, the soft with the hard, the organic with the non-organic.

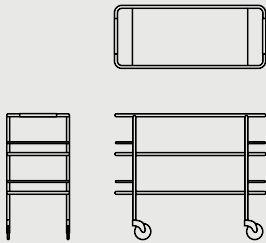

Trolley

1999

Frame of 16 mm chromium plated or powder coated steel tubing incl. black casters. 3 shelves of white or black laminate, frosted glass or leather or in combination, e.g. glass-laminate-laminate, glass-leather-leather etc. Handles in leather.

Height: 700 mm

Width: 840 mm

Depth: 350 mm

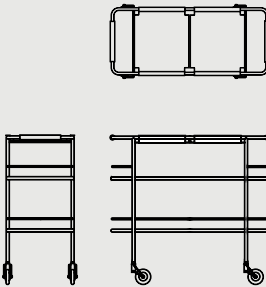

Cargo Gastro

Trolley

2011

Frame of Ø16 mm chromium plated steel tubing incl. casters. 2 shelves in white or black laminate alt. frosted glass. Includes 2 small trays or 1 big tray in stainless steel with marble plate. Handles in leather. Casters with polyurethane-tyre.

Height: 790 mm

Width: 840 mm

Depth: 390 mm

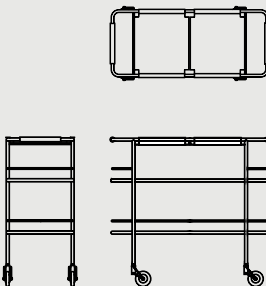

Cargo Support

Trolley

2007

Frame of Ø16 mm chromium plated steel. Shelves of laminate, (black/white), frosted glass or combined. Top shelf with 2 trays 290x323 mm alt. 1 tray 578x323 mm in stainless steel with black rubber cloths. Handles in leather. Casters with polyurethane-tyre.

Height: 790 mm

Length: 840 mm

Width: 390 mm

CAROUSEL

Design: Gunilla Allard

Meetings tend to drag on, at times. But with Carousel, one is quite happy to sit there a while longer, pleasantly embraced by the chair's generous backrest and winglet-shaped armrests. A compactly designed yet unexpectedly comfortable conference chair, Carousel is equipped with a 360° swivel-tilt feature that affords multi-directional freedom — so the occupant can move about smoothly and flexibly.

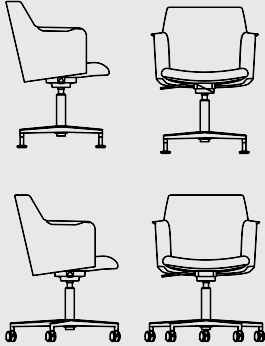

Armchair

2018

4-foot or 5-foot swivel base, 360°, of polished or powder coated recycled aluminum. Pillar always in chrome or black powder coat. Glides or casters in chrome or black powder coat. Molded back with high resilient polyurethane foam. Seat of molded plywood with high resilient polyurethane foam. Incl. 360° comfort tilt. Additional: height adjustable frame (not for 4-feet with casters).

Height: 810/760–890 mm

Width: 620/640 mm

Depth: 620/640 mm

Seat height: 460/410–540 mm

CHICAGO

Design: Gunilla Allard

Chicago is a furniture piece marked by keen attention to detail. Its handsome casters are a signature element of designer Gunilla Allard. Chicago is available in two versions: Chicago I, a small side table with three shelves, and the larger but lower Chicago III, with two shelves, that may be used as a sofa table.

Trolley

1999

Frame of Ø16 mm chromium plated or powder coated steel tubing incl. black casters. Shelves of white or black laminate, frosted glass or leather or in combination, e.g. glass-laminate-laminate, glass-leather-leather etc.

Height 430/570 mm

Width: Ø540/900 mm

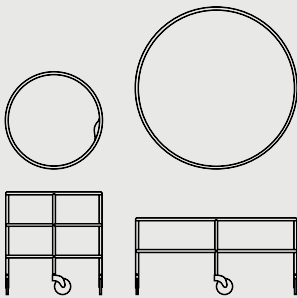

CINEMA

Design: Gunilla Allard

The Cinema easy chair made its debut at Milan's Salone del Mobile in 1993. Today it is one of the most iconic pieces in the Lammhults portfolio. Cinema has a character all its own — and one that remains relevant almost thirty years on. It is a furniture piece that expresses fluidity. A sense of being on the move, despite being entirely static. Inspired by the seats of classic sports cars, Cinema is available both as an armchair and a sofa.

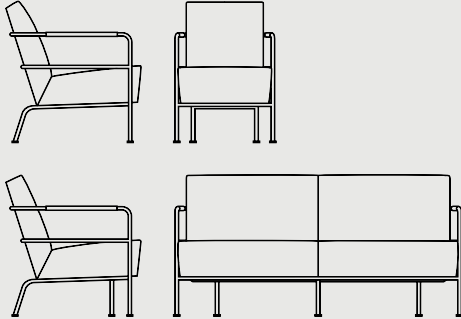

Easy chair/Sofa

1994

Frame of Ø16 mm and 19 mm powder coated or chromium plated steel tubing. Seat with nosag springs. Seat and back with injected expanded polyurethane foam. Leather arm covers.

Height: 780 mm

Width: 560/1600 mm

Depth: 750 mm

Seat height: 420 mm

COOPER

Design: Gunilla Allard

Gunilla Allard's works are filled with allusions to architectural and design history, as well as to film and popular culture. In the case of her Cooper table, an innovation that invaded people's living rooms in the mid-20th century informs the shape of its table top. "I was inspired by the TV screens of the sixties, with those rounded corners," remarks Allard.

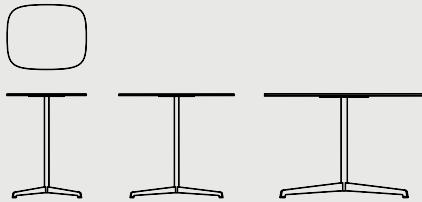

Table

2004

Frame of chromium plated or powder coated steel. Table top of 10/12 mm white compact laminate with black edge or 16 mm MDF with oak veneer and edge in oak.

Height: 450/520/720 mm

Width: 550/800/1100 mm

Depth: 450/700/1000 mm

CORSO

Design: Peter Andersson

It is no coincidence that Corso's capricious lines recall the swift spontaneity of pen strokes. That was exactly how the idea for its design was born, explains designer Peter Andersson. "The two-dimensional lines in my sketchbook — which just felt so intuitive and obvious as I drew them — are what ultimately became a contiguous loop of steel tubing." Corso is an easy chair made of high-quality materials and designed to last. Its imaginative style is flamboyant yet utterly elegant.

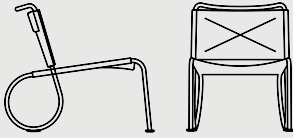

Easy chair

2021

Frame of $\varnothing 22$ mm powder coated or chromium plated steel tubing. Seat and back of black canvas with black leather details, incl. high resilient polyurethane foam cushions in black canvas or leather alt. seat and back of natural linen with natural leather details incl. high resilient polyurethane foam cushions in natural linen or leather.

Height: 770 mm

Width: 645 mm

Depth: 900 mm

Seat height: 390 mm

FUNK

Design: Johannes Foersom & Peter Hiort-Lorenzen

Characterised by a clean, functional design, the Funk table's exuberant, naive style is most clearly expressed when its cast aluminium frame is powder-coated in bold colours. Alternatively, a polished finish lends it a more subdued and ascetic look. Funk's frame is made of recycled aluminium, while its top is available in a range of finishes and sizes. Funk works equally well as a dining table, a work table, or a conference table.

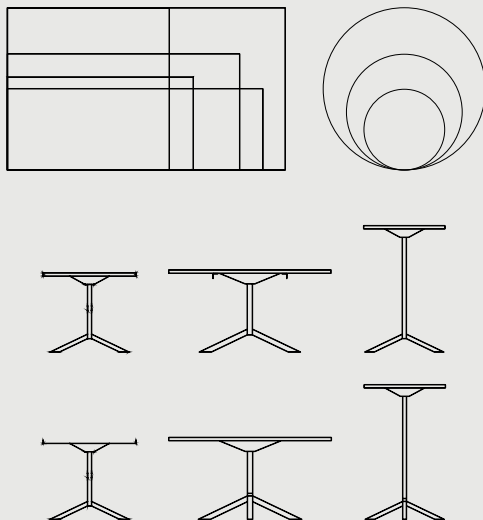

Table

2008

Table top of 28 mm fibre board in the following versions:

- Melamine: white/grey or graphite with matching plastic edge.
- Ash: Natural or stained, white/grey or graphite, with matching wooden edge.

Frame of powder coated or polished cast recycled aluminum. Adjustable feet. Rectangular tables can be linked. Wiring possible in pillars. Other versions on request.

Length: 1200/1600/2200/2000/2400 mm

Width: 800/1000/1200/1400 mm

$\varnothing 700/1000/1200/1400$ mm

GRADE

Design: Johannes Foersom & Peter Hiort-Lorenzen

Grade is a series of chairs that references both modernism and nature. Made of recycled polypropylene, its comfortable, moulded seat shell features a relief pattern that suggests the layers of a sea shell formed over time. Grade is available in a variety of iterations, with or without armrests. The more generously sized Grade Plus features armrests that are an integral part of its moulded seat shell.



Barstool

2016

Frame of $\varnothing 14$ mm powder coated or chromium plated steel tubing. When powder coated, the frame matches the color of the seat. Seat shell of recycled polypropylene in white grey, graphite, beige, blue green or dark red. Optional seat pad or fully upholstered shell.

Height: 990/1120 mm

Width: 480/520 mm

Depth: 540/550 mm

Seat height: 660/790 mm



Chair/Armchair

2014

Frame of $\varnothing 14$ resp. $\varnothing 16$ powder coated or chromium plated steel tubing alt. solid ash. When powder coated, the frame matches the color of the seat. 4-foot and 5-foot swivel base, 360° , with feet of cast recycled aluminum and pillar with $\varnothing 40$ mm recycled aluminum cover. Glides. Casters as an option. Seat shell of recycled polypropylene in white grey, graphite, beige, blue green or dark red. Optional upholstered seat, or fully upholstered shell.

Stackable and linkable.

Height: 780/770–870 mm

Width: 480/510/530/570/580/670/700 mm

Depth: 540/640/670 mm

Seat height: 490 mm

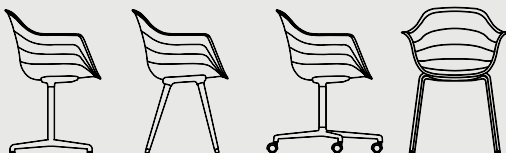

Grade Plus

Armchair

2019

Frame of $\varnothing 16$ powder coated or chromium plated steel tubing alt. solid ash legs. 4-foot and 5-foot swivel base, 360° , with feet of cast recycled aluminum and pillar with $\varnothing 40$ mm recycled aluminum cover. Glides. Casters as an option.

Seat shell of polypropylene with integrated armrests in white grey, graphite, beige, dark red or black. Additional upholstered seat and felt glides.

Height: 800/880 mm

Width: 590/700 mm

Depth: 550/670 mm

Seat height: 460 mm

PENNE

Design: Julia Läufer & Marcus Keichel

In designing Penne, Julia Läufer and Marcus Keichel reinterpreted Lammhults' most characteristic material element, the steel tube, with recycled aluminium. These slightly thicker tubes evoke iconic Lammhults furniture by Börge Lindau and Bo Lindekrantz, while the choice of materials results in a chair that is significantly lighter. The seat and the back are available in wood — moulded natural oak & ash or stained ash— or in white, grey or black polypropylene.

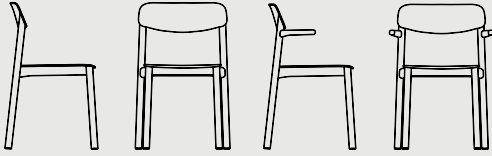

Chair/Armchair

2017

Frame of powder coated Ø35 mm aluminum tube. Glides. Armrest in white, grey or black polyamide. Seat and back of molded natural ash or oak or stained ash alt. seat and back in white, grey or black polypropylene. Seat frame of white, grey or black polyamide. The color of the zinc fitting of the backrest matches the color of the seat frame. Stackable incl. stacking protection. Linkable chair-chair or armchair-chair-armchair.

Height: 790 mm

Width: 510/570 mm

Depth: 500 mm

Seat height: 460 mm

PLANKA

Design: Börge Lindau & Bo Lindekrantz

Planka is perhaps the most idiosyncratic piece of furniture ever designed by Börge Lindau and Bo Lindekrantz. It uncompromisingly expresses all their hallmarks as designers: humour, ingenuity, naivety and optimism. As much a sculpture as it is a chair, Planka is a postmodernist work that turns heads and sparks conversation. The idea behind Planka arose in 1985. At the beach one day, Lindau spotted a sunbather with his back resting against a plank and a rolled-up towel supporting his neck. Planka swivels 360° and features an adjustable headrest.

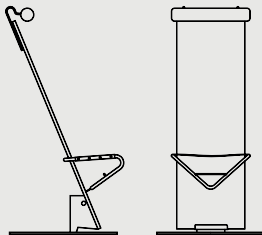

Chair

1985

Swivel base with foot plate of powder coated steel. Seat of perforated sheet metal or upholstered in black coach hide leather. Back of lacquered wood alt. upholstered in black coach hide leather. Neck cushion in leather. Frame for seat and neck cushion always in chromed steel tubing.

Height: 1060/1200 mm

Width: 410 mm

Depth: 700 mm

Seat height: 420 mm

PONTO

Design: Troels Grum-Schwensen

Ponto is the Esperanto word for bridge. With a maximum length of 558 cm, or over 18 feet, the Ponto table is undeniably reminiscent of its namesake. And just like a bridge, it is designed to facilitate meetings. Its concept also links craftsmanship and natural materials with technology. The legs are made of solid wood and milled to slide neatly into the recycled aluminium frame beneath the table top. The frame, in turn, supports the entire table, ensuring that no more than four legs are ever needed, regardless of the table's length.

Table

2019

Legs of solid natural or stained ash. Frame of extruded recycled aluminum. Table top of 28 mm wood fibre board in the following versions:

- Veneer: Natural ash or stained ash with matching wooden edge.
- Linoleum: Nero alt. Iron with matching plastic edge when possible.

Additional deviating wooden edge in oak, ash, or walnut at an additional cost.

Height: 740 mm

Width: 2900/3600/4200/4800/5580 mm

Depth: 1000/1200/1400 mm

Ø1600/1800 mm

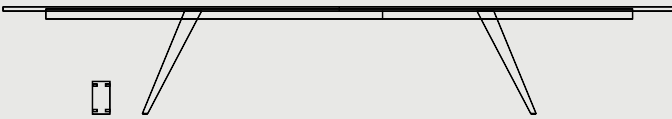
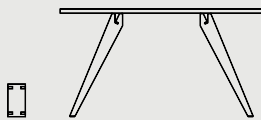
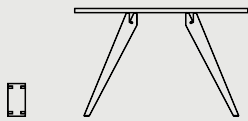
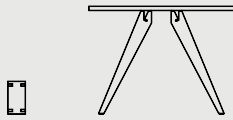
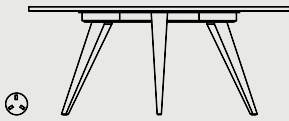

PORTUS

Design: Johannes Foersom & Peter Hiort-Lorenzen

While enabling a wide variety of spatial functions, Portus ensures a cohesive style. It consists of a few basic components: a soft bench, a rounded backrest, an ergonomic lumbar cushion or decorative pillows. The resulting furniture pieces serve as architectural building blocks to create spaces for meetings and conversations, as well as secluded settings for reflection and rest. Portus is available in two different heights. The high-back version is ideal for creating private space and improving acoustics.

Bench/Easy chair/Sofa

2015

Legs of powder coated or chromium plated Ø35 mm steel tubing alt. natural or stained ash. Glides. Seat frame of massive wood and molded high resilient polyurethane foam. Back of molded wood and high resilient polyurethane foam incl. quilting on the outside. Back cushion of high resilient polyurethane foam alt. decoration pillows. When upholstered in 2 colors the back cushion follows the color of the seat.

Height: 420/790/1320 mm

Width: 820/990/1040/1370/1550/1600/2120/2300 mm

Depth: 750/840/850 mm

Seat height: 420 mm

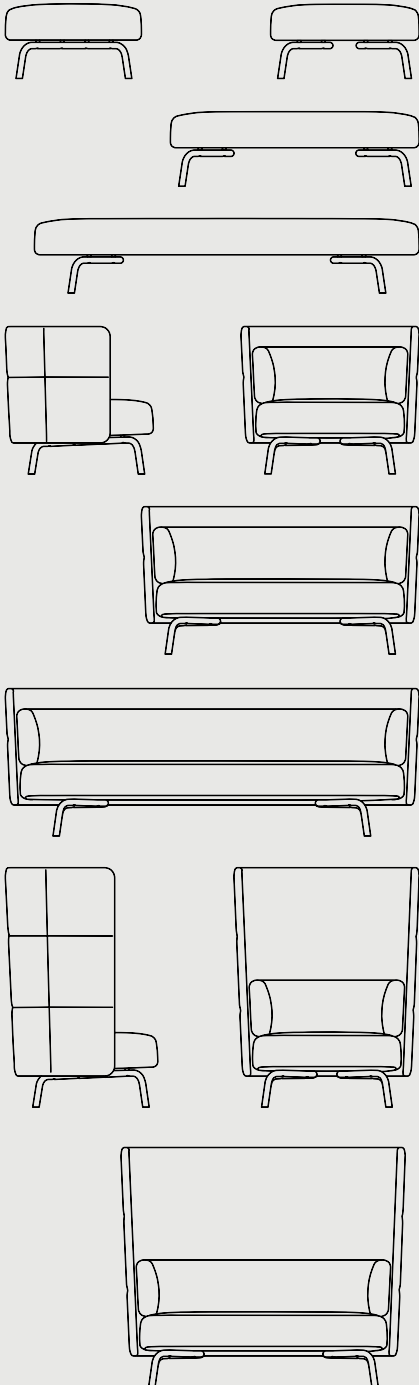

QUICKLY

Design: Johannes Foersom & Peter Hiort-Lorenzen

The Quickly table was designed for spaces that require frequent, rapid transformation. Whether it's a start-up business, a coworking office, or a hybrid workplace, Quickly makes modifying any environment a snap. Create several work stations one moment — and remove them the next. Quickly is a compactly constructed folding table with a quick-lock mechanism that makes it easy for one person to set it up and fold it flat.

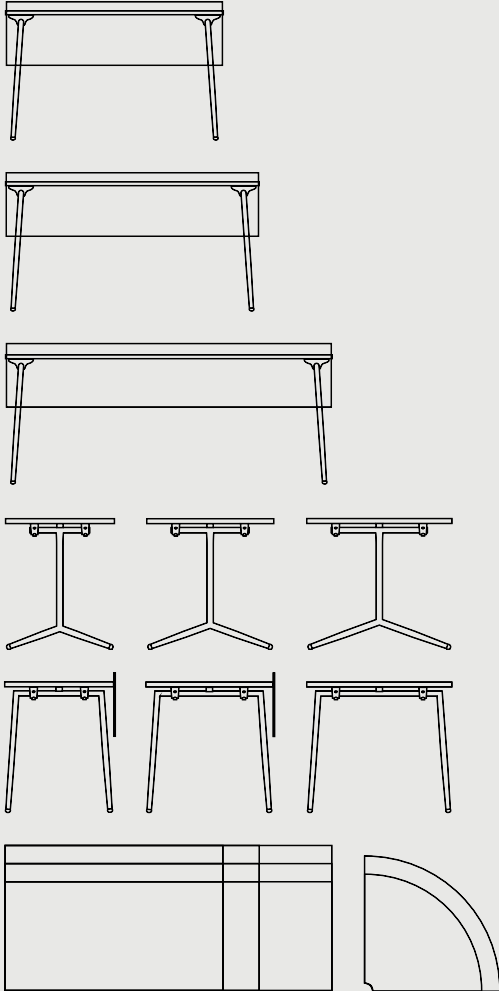

Table

2000/2012

Foldable powder coated or chromium plated frame of $\varnothing 30$ mm welded conical steel tubing. Foldable T-leg frame of $\varnothing 30$ mm welded conical steel tubing available as option.

Table top:

Flexible, of 25 mm poplar plywood with high pressure laminate K2010 UN, white/grey with light grey plastic edge. Alt. birch veneer with matching wooden edge.

For some sizes the following table top is available: Basic, of 22 mm MDF with melamine, white/grey with matching plastic edge.

Sizes/materials:

Flexible — Laminate

1200x500, 1200x600, 1200x700, 1400x500, 1400x600, 1400x700, 1800x600, 1800x700 mm

Corner table top: 600x600, 700x700 mm

Flexible — Birch veneer

1200x500, 1200x600, 1200x700, 1200x800, 1400x600, 1400x700, 1400x800, 1800x600, 1800x700, 1800x800 mm

Corner table top: 600x600, 700x700 mm

Basic — Melamin

1200x500, 1200x600, 1400x600, 1200x500, 1200x700, 1400x700 mm

Corner table top: 600x600, 700x700 mm

S70

Design: Börge Lindau & Bo Lindekrantz

When it appeared on the scene in 1968, the radically designed S70 furniture series raised plenty of eyebrows. Today, more than fifty years later, its refreshingly irreverent pop-culture look makes it surprisingly relevant. This is furniture that still manages to lighten the mood of a room — whose bright colours and thick, charmingly clunky steel tubes bring a smile to your face. The bold icon of the series, the S70 barstool, consists of a single steel tube bent into an S. For designers Börge Lindau and Bo Lindekrantz, S70 was the big breakthrough; for Lamphults, it was what advanced them into the premier division of furniture design.

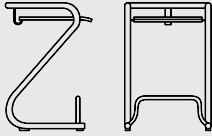

S70-3

Barstool

1968

Frame of 32 mm chromium plated or powder coated steel tubing. Footrest always in chrome. Seat of plywood with natural birch veneer alt. lacquered in black, white or grey. Other colors on request. Alt. upholstered seat. Stackable.

Height: 710 mm

Width: 480 mm

Depth: 480 mm

Seat height: 630 mm

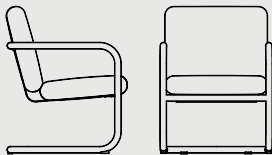

S70-4

Easy chair

1968

Frame of 35 mm chromium plated or powder coated steel tubing. Glides. Cushions of high resilient polyurethane foam.

Height: 810 mm

Width: 620 mm

Depth: 620 mm

Seat height: 420 mm

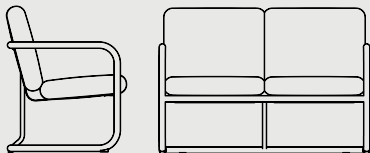

S70-5

Sofa

1968

Frame of 35 mm chromium plated or powder coated steel tubing. Glides. Cushions of high resilient polyurethane foam.

Height: 810 mm

Width: 1170 mm

Depth: 620 mm

Seat height: 420 mm



S70-12

Coat hanger

1968

Frame of 35 mm powder coated steel tubing. Foot of powder coated steel. Rotating top with 7 hooks with plastic end caps.

Height: 1700 mm

Width: 400 mm

Depth: 400 mm

SPIRA

Design: Johannes Foersom & Peter Hiort-Lorenzen

Spira is a chair designed for expansive contexts and spaces where large numbers of people gather, such as auditoriums, reading rooms, seminar rooms and conference venues. As these are settings in which people can remain seated for several hours, comfort is a key design goal. Another, however, is ensuring that the seats do not take up too much space. "We knew it had to be an upholstered chair but still usable as a volume chair — with volume-chair features, like linking and stacking," says Johannes Foersom. The seat and back are available in several finishes: fabric or leather upholstery, quilted upholstery, and non-absorbant polyurethane.

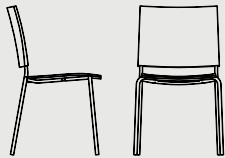

Chair/Armchair

2004/2020

Frame of Ø18 mm chromium plated steel tubing. Armrests in dark or light woodfibre. Spring steel in back. Back of natural ash, birch or oak alt. stained ash, or black cast polyurethane or upholstered. Seat of black cast polyurethane or upholstered with high resilient polyurethane foam incl. stacking protection.

Height: 830 mm

Width: 510/550 mm

Depth: 560 mm

Seat height: 450 mm

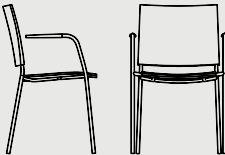

Chair/Armchair swivel base

2013

Base, 360°, of Ø18 mm powder coated or chromium plated steel tubing incl. chromed casters. Upholstered seat with high resilient polyurethane foam incl. stacking protection. Upholstered back or back of natural ash, birch or oak. Alt. stained birch as standard, stained ash on request. Back in black polyurethane on request. Armrests in dark or light woodfibre

Height: 830 mm

Width: 570/610 mm

Depth: 560/580 mm

Seat height: 450 mm

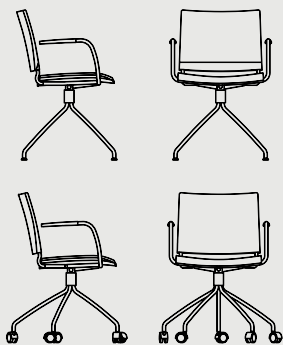

SUNNY

Design: Gunilla Allard & Note Design Studio

Sunny is the outcome of a meeting between the legendary Gunilla Allard and Note Design Studio's Kristoffer Fagerström and Joel Fjällström — three designers of different generations, each with her or his own set of references and perspective on design. Hence, Sunny's creation was influenced from many directions, including the cinema, contemporary fashion, and mid-20th century architecture. Sunny articulates a freer and less formal way of relating to space. The concept is scalable and can be used to furnish smaller, as well as larger, spaces. The seat can be employed as a solitary lounge chair or as a modular component in a variety of sofa configurations. The concept also includes tables.

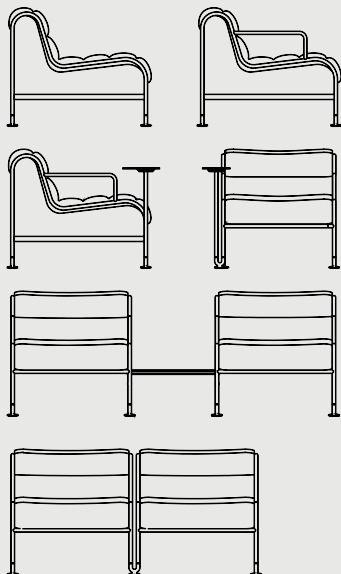

Easy chair & modular seating

2021/2022

Frame in Ø20 mm powder coated or chromium plated steel tubing, feet in die-cast zinc, Teflon glides. Support fabric in black canvas or natural linen, cushions with 25% RBS-certified seabird feather and 75% grated cold foam. The easy chair is also available with a fixed side table on the right or left with braces and table top of 5 mm sheet steel that match the finish of the frame. Table top in blue or white recycled plastic is available as an option. Linking table 30° or 760x560 cm, in white high pressure laminate or black Perfect Sense melamine.

Height: 700 mm

Width: 800 mm

Depth: 840 mm

Seat height: 390 mm

TABURETT

Design: Edvin Ståhl

A reissue of one of Lammhults' earliest products, the 282 stool, designed in 1955 by founder Edvin Ståhl, Taburett embodies modernist ideals, such as democratic design, simplicity, and rationality. The stackable stool differs from its forebear in just one detail: Its seat features a powder-coated or chromium-plated die-cast zinc fastener cap embossed with an L for Lammhults. A barstool in two heights is also available.

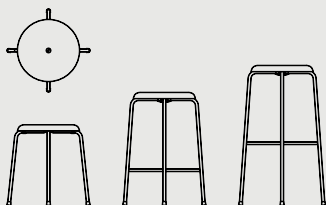

Stool/Barstool

1955/2014

Frame of 16 mm chromium plated or powder coated steel tubing. Seat of white, grey, black, red or orange ABS plastic alt. upholstered. Embossed seat detail of powder coated or chromium plated die-cast zinc. The stool is stackable.

Height: 450/630/780 mm

Width: 460/480 mm

Depth: 460/480 mm

TEIUS

Design: Andrés Nilson

Teius enables truly site-specific seating solutions. A stand-alone bench serves as the starting point of its modular concept. By attaching more benches, as well as armrests, backrests, and other modules, you can build formations precisely adapted to any space. You can also combine different colours amongst the system's modules or create entirely monochrome seating solutions.

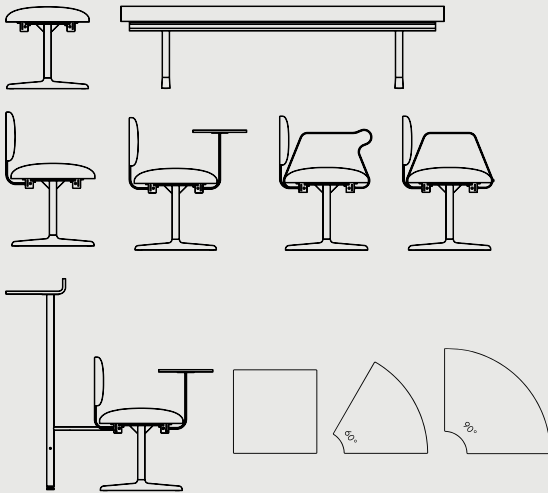

Modular seating

2020

Teius is a circular piece of sectional furniture in the form of a bench or sofa, which can be infinitely shaped and extended using connecting tables, armrests, high tables, power solutions and so on. The construction is based on an aluminum profile, and the various parts such as legs, seat, backrest etc. slide onto the profile and are simply screwed in place.

Options: Polished aluminum foot, texture powder coated armrest or armrest with raising aid, linking device back to back, wall spacer, floor anchor. Stand table, 1200x330 mm, 16 mm ash veneer, natural or stained in white or black with texture powder coated frame. (Not in combination with bench 1200 mm incl. back). Side table Ø300 mm in white or black compact laminate with texture powder coated arm. Connecting table in 12 mm white or black compact laminate with texture powder coated arm:

- Square 45x45
- 60°
- 90°

Height: 740/780/910 mm

Width: 1200/1800/2400 mm

Depth: 450/500 mm

Seat height: 460/500/630 mm

TRIOO

Design: Johannes Foersom & Peter Hiort-Lorenzen

Trio is three different chairs in one. The concept is the brainchild of design team Johannes Foersom and Peter Hiort-Lorenzen. Their idea of a chair with three different characters sprang from a desire to create a single form suited to different ergonomic needs. Trio thus consists of a frame, a seat, and three different backs, which together give the chair several functions and looks. Its essential shape is inspired by oyster shells. Trio is made of high-quality materials, and its parts are easily replaced in the course of maintenance and repair.

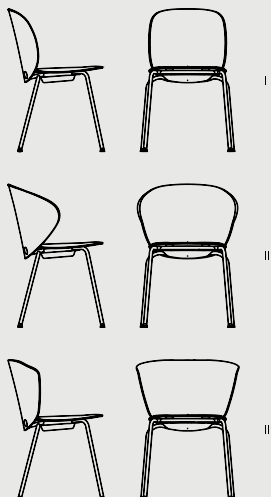

Chair/Armchair

2021

Frame of Ø18 mm powder coated or chromium plated steel tube. Seat and back of natural ash or oak alt. stained ash. Three different backs. Glides. Option upholstered seat. Stackable incl. stacking protection.

Height: 770/790 mm

Width: 520/550/560 mm

Depth: 540 mm

Seat height: 460 mm

X75

Design: Börge Lindau & Bo Lindekrantz

The X75 series was launched in 1975, having been designed by pipe-smoking duo Börge Lindau and Bo Lindekrantz, who left their mark on Lammhults style for many years. Foldability has always been the functional hallmark of the X75 series of products. In aesthetic terms, they express optimism and individuality, both qualities being evident in the X75-2 folding chair. Its seat and back are made of canvas. And though its tubular steel frame is also available with a chrome or powder-coated finish, the cross-tubing is always black for the sake of clarity.

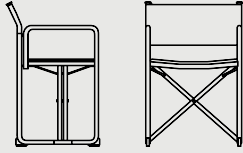

X75-2

Armchair

1972

Foldable frame of 25 mm chromium plated or powder coated steel tubing. Cross tubing always powder coated in black. Upholstery in black or grey canvas alt. natural linen. Seat with reinforcements in matching leather.

Height: 800 mm

Width: 530 mm

Depth: 510 mm

Designers

Andrés Nilson	128
Anya Sebton	104-107, 109-111
Börge Lindau & Bo Lindekrantz	121, 125-126, 129
Edvin Ståhl	127
Gunilla Allard	112-113, 116-118
Gunilla Allard & Note Design Studio	127
Johannes Foersom & Peter Hiort-Lorenzen	107-109, 111, 113-115, 119-120, 123-124, 126, 128
Julia Läufer & Marcus Keichel	107, 121
Peter Andersson	119
Troels Grum-Schwensen	112, 122









Credits

Design & Production:
tätatät®

Creative & Set design (Space Matters):
Atelier Paul Vaugoyeau

Photography (Space Matters):
Erik Lefvander

Copywriting:
Jens Soneryd

Print:
Taberg Media Group

Binding:
Förlagshuset Nordens Grafiska

Cover:
Fedrigoni
Sirio Color, Arancio, 210 g/m²

First & Last insert:
Arctic Paper
Artic Volume White, 130 g/m²

Second insert & Appendix:
Arctic Paper
Munken Lynx Rough, 90 g/m²

Typeface:
Futura PT by Paratype
Original design by Paul Renner

Showrooms

Lammhults
Visitor address
Växjövägen 41
SE—363 45 Lammhult
Sweden
Phone +46 (0)472 269500

Postal address
Box 26
SE—363 03 Lammhult
Sweden

Stockholm
Adolf Fredriks Kyrkogata 15
SE—111 37 Stockholm
Sweden
Phone +46 (0)472 269500

Gothenburg
Studio L6, Lasarettsgatan 6
SE—411 19 Göteborg
Sweden
Phone +46 (0)31 138390

Malmö
Skeppsbron 3
SE—211 20 Malmö
Sweden
Phone +46 (0)709 28 11 15

Copenhagen
Sankt Jørgens Allé 5, 2. Sal Th,
DK—1615 København
Denmark
Phone +45 (0)24 59 89 59

Oslo
Pilestredet 75C, Inngang 38
NO—0354 Oslo
Norway
Phone +47 (0)92 65 67 34

Paris
5 Bis Rue Gabriel Laumain
FR—75010 Paris
France
Phone +33 609 782 730

Woerden
All Art Kwast Agencies
Polanerzandweg 1
NL—3446 CC Woerden
The Netherlands
Phone +31 348 44 33 23

